

INSTALLATION INSTRUCTIONS

IMPORTANT!

Incorrect installation will void your warranty

- Bailey Water Tanks are to be used only for storing water at ambient temperature.
- Delivery is to the road entrance of your property (providing access is suitable).
- Transportation to the site is at the driver's discretion.
- Installation is the responsibility of the purchaser.

Site Preparation

The site should be **firm, level, stable** ground. It should be at least 600mm greater in diameter than the tank. The base should be adequately and uniformly supported over its whole area. Do not place the tank on beams with interval spaces. Ensure that the area is free from any sharp objects such as stones or roots. A concrete pad or 100mm deep compacted sand is recommended and should also be 600mm greater in diameter than the tank. If using sand it should be boxed in with 4x2 timber to avoid erosion. If locating the tank on a sloping section make sure that the area will not erode and do not backfill against the tank.

- **The tank is not to be buried.**
- **Do not walk or put weight on the dome of the tank this is unsafe and could also damage the tank.**

Plumbing

A 50mm BSP outlet is fitted to the base of the tank ready for you to screw in your fittings, a reducing bush / nipple can be fitted if required.

No extra penetrations are to be cut into the sidewalls of the tank without written consent from the manufacturer. No penetrations are to be cut into the base.

A specially moulded box with flat sides is conveniently located to the front of the inspection hatch at the top of the tank. All fittings: inlet, overflow, ballcock, water level indicator etc should be installed here. Therefore it is not necessary to walk on the dome.

Connection between the tank and pump should include a flexible hose (not polyethylene pipe) to absorb vibration.

If connecting multiple tanks together or connecting a tank to a rigid structure, flexible hose should be used or a 90-degree loop to allow for expansion or shrinkages.

Pipe the overflow away from the foundation to prevent erosion.

The cap in the middle of the dome is used during manufacture and should not be used for installation. Do **not** remove this cap.

The lid is vented and offset for ease of inspection.

PLEASE NOTE a 30,000L tank weighs 30 tonne when full so take care with preparation of the site and the installation of the tank.

Authorised Bailey Tank agents may in certain circumstances deviate from these instructions providing they stay within the manufacturers guidelines.



Site Preparation

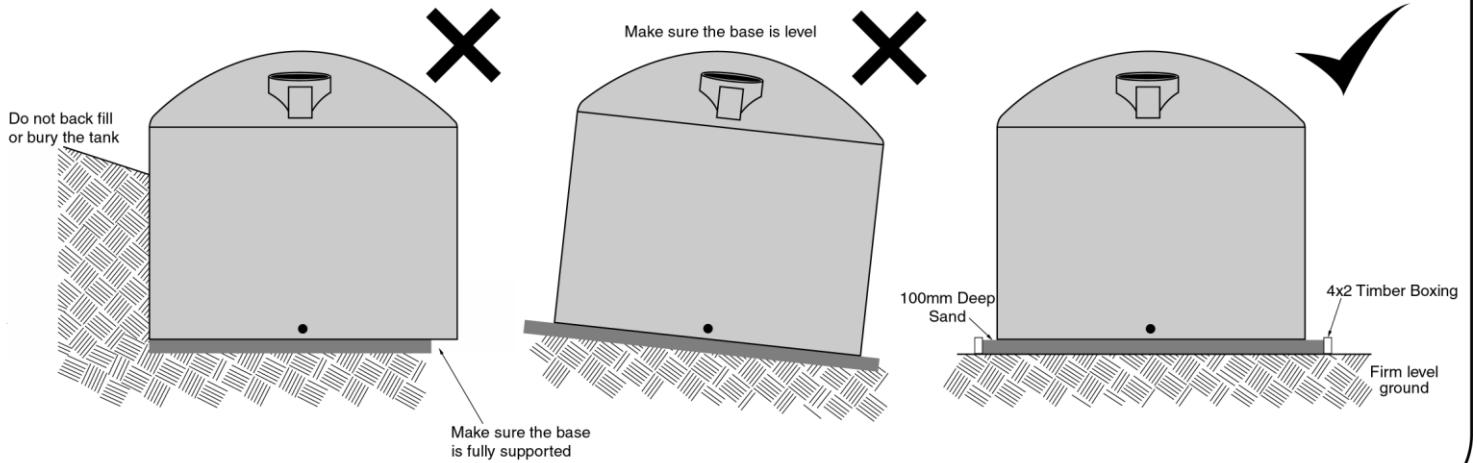

Plumbing

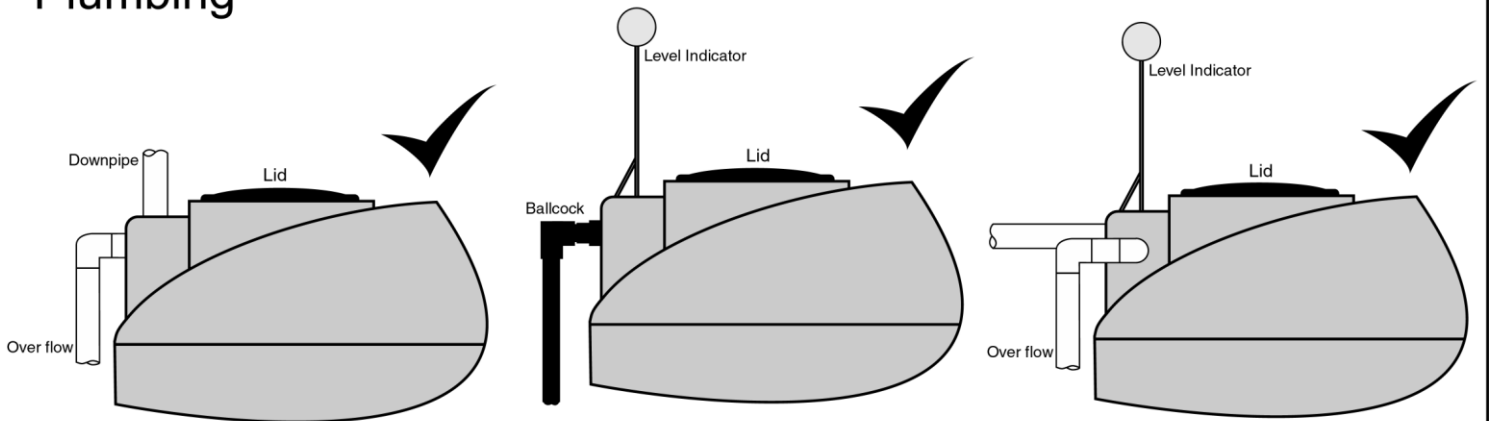

Lifting

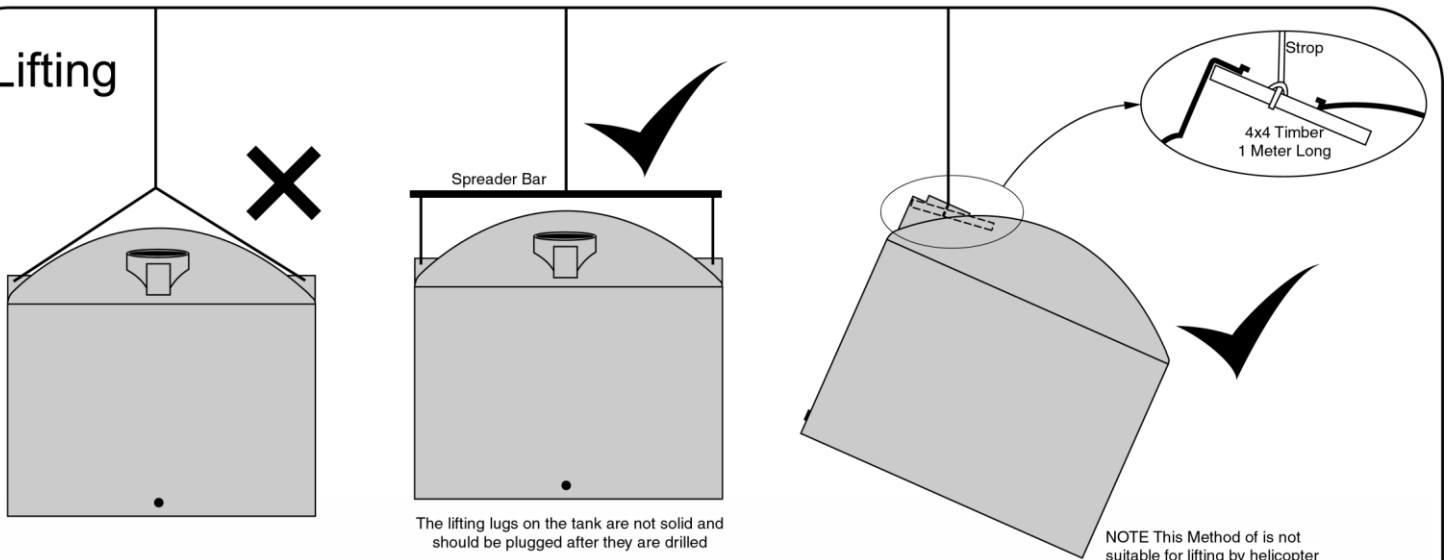

When lifting the tank must be completely empty