

# SOLOLIFT2 WC-1, WC-3 & CWC-3



COMPACT GREY WATER AND BLACKWATER HANDLING STATION

## WATER SOURCE



Blackwater      Grey Water

## APPLICATION



Blackwater Handling      Grey Water Handling

- Options to suit most domestic applications
- Thanks to the **powerful built-in grinder** blockages are greatly minimised
- **Space saving design** allow these units to be installed in small spaces
- Highly **flexible connections** make for **low cost installation**



SOLOLIFT2 WC-1

SOLOLIFT2 WC-3

SOLOLIFT2 CWC-3

## SOLOLIFT2 SELECTOR

WC-1



Single Floor Mounted Toilet + **ONE** additional source

WC-3



Single Floor Mounted Toilet + **THREE** additional sources

CWC-3



Single Wall Mounted Toilet + **THREE** additional sources

	WC-1	WC-3	CWC-3
Floor Mounted Toilet	●	●	
Wall Mounted Toilet			●
Handbasin	●	●	●
Shower		●	●
Bath		●	●

● Suited to this type of toilet installation (Floor or Wall Mounted)

● Choose from any combination of these additional sources up to the maximum number of inlets available

## FIND SPACE FOR YOUR PUMP

The SOLOLIFT2 range has been designed to fit into confined spaces. See below the space required for the installation of each model in the WC-1, WC-3 & CWC-3 range.

### WC-1 & WC-3

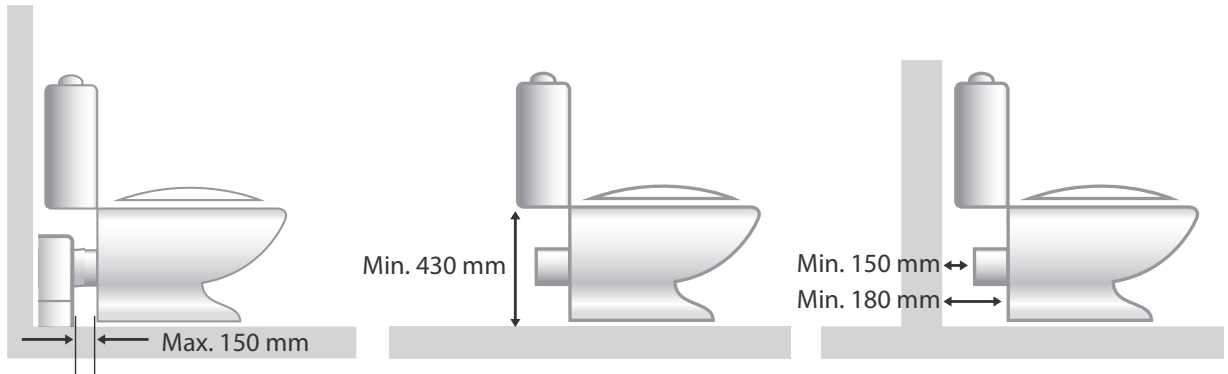

### CWC-3

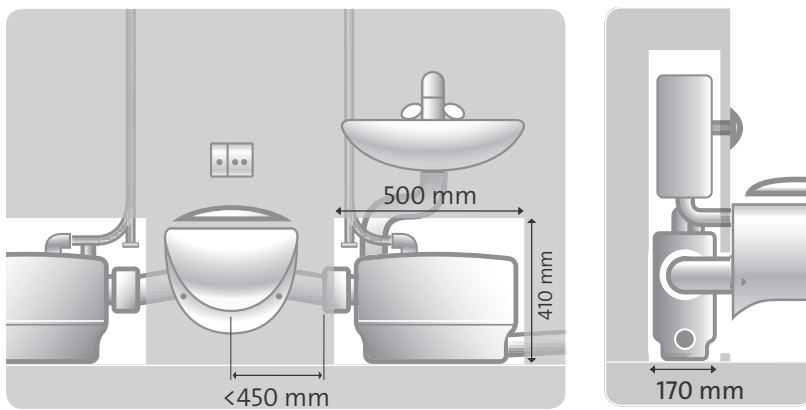

### WC-1 & WC-3

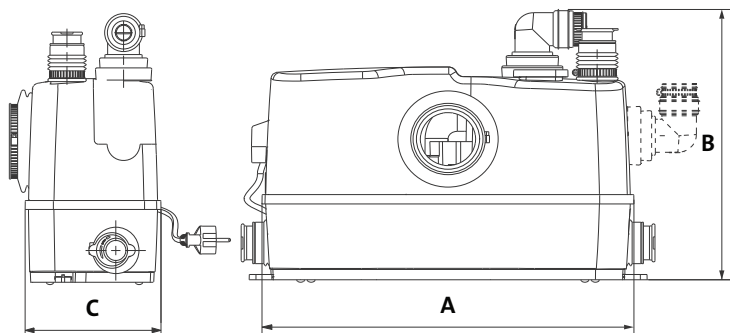

### CWC-3

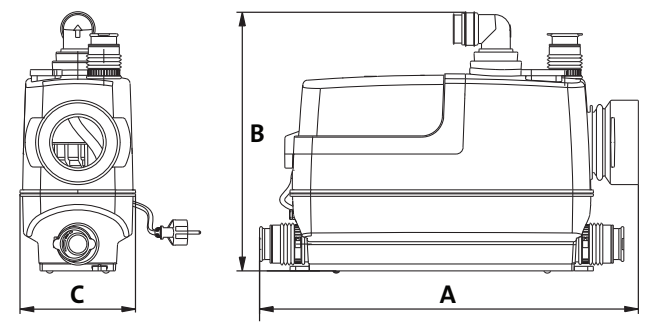

Model	Dimensions (mm)		
	A (l)	B (h)	C (w)
SOLOLIFT2 WC-1	442	346	176
SOLOLIFT2 WC-3	442	346	176
SOLOLIFT2 CWC-3	539	368	164